

SUBDIVISION REVIEW SHEET**CASE NO.:** C8-2018-0005**PC DATE:** February 12, 2019**SUBDIVISION NAME:** Charles Schwab Campus Preliminary Plan**AREA:** 50.4 acres**LOTS:** 2**APPLICANT:** CS Kinross Lake Parkway, LLC (Brian Colonna)**AGENT:** Garza EMC (John Pelham)**ADDRESS OF SUBDIVISION:** 2309 Gracy Farms Road**GRIDS:** MK34**COUNTY:** Travis**WATERSHED:** Walnut Creek**JURISDICTION:** Full Purpose**EXISTING ZONING:** NBG-NP (North Burnet/Gateway Zoning District)**DISTRICT:** 7**LAND USE:** Commercial**NEIGHBORHOOD PLAN:** North Burnet**SIDEWALKS:** Sidewalks will be constructed along Schwab Way and Gracy Farms Way.**DEPARTMENT COMMENTS:** The request is for approval of the Preliminary Plan of Charles Schwab Campus, comprised of two lots on 50.4 acres. The applicant proposes to resubdivide an existing lot into two lots for commercial use. Lot 2 will contain a private street (Schwab Way) and Lot 1 will contain the existing structures. The proposed lots comply with zoning requirements for use, lot width and lot size.**STAFF RECOMMENDATION:** The staff recommends approval. The preliminary plan meets all applicable State and City of Austin Land Development Code requirements.**PLANNING COMMISSION ACTION:****CASE MANAGER:** Steve Hopkins**PHONE:** 512-974-3175**E-mail:** steve.hopkins@austintexas.gov

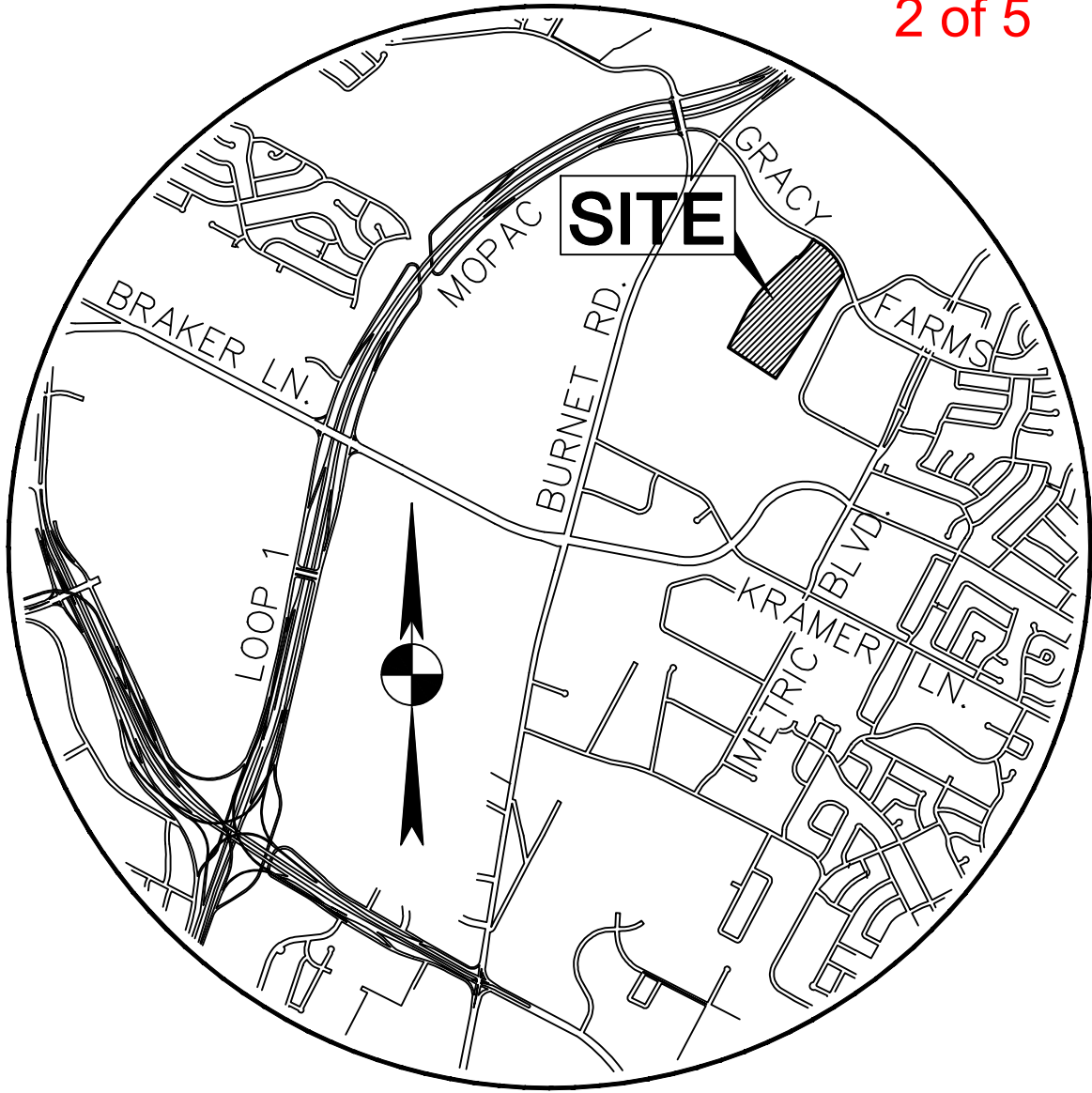

VICINITY MAP

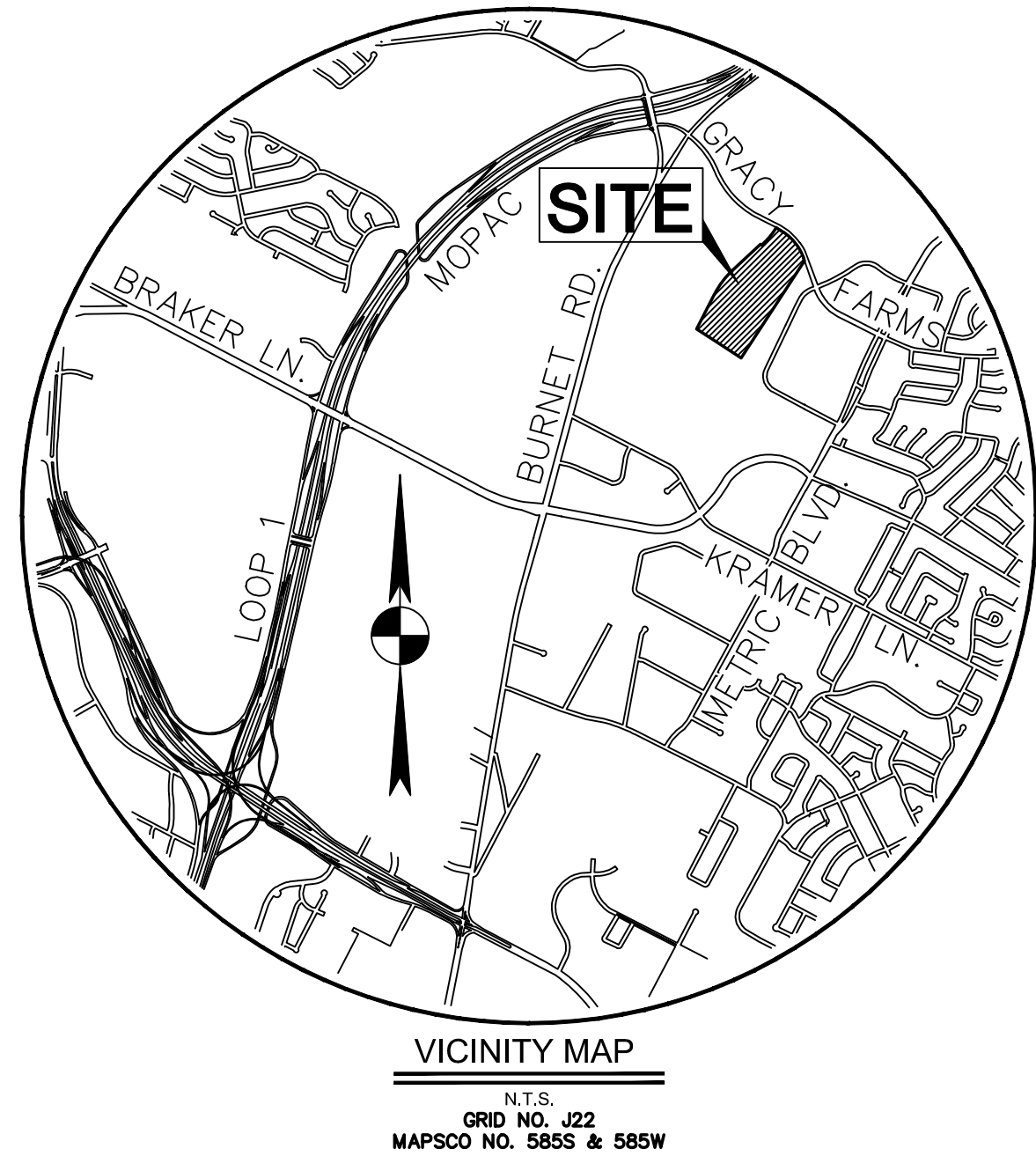

SHEET INDEX ON SHEET 1

SHEET NO.	DESCRIPTION
1	COVER
2	PRELIMINARY PLAN GENERAL NOTES
3	PRELIMINARY PLAN

CHARLES SCHWAB SUBDIVISION PRELIMINARY PLAN

OWNER: STEVEN BELL
CS KINROSS LAKE PARKWAY, LLC
211 MAIN STREET
SAN FRANCISCO, CA 94105
(512) 845-8921

ARCHITECT: PAGE SOUTHERLAND PAGE
400 W. CESAR CHAVEZ STREET, SUITE 500
AUSTIN, TX 78701
(512) 472-6721

ENGINEER: GARZA EMC
7708 RIALTO BLVD, SUITE 125
AUSTIN, TX 78735
(512) 298-3284

SUBDIVISION NO : C8-93-0029.OA

ADDRESS : 2309 GRACY FARMS LANE
AUSTIN, TEXAS 78758

SUBMITTAL DATE : 01/11/2018

SUBMITTED BY :  DATE
JOHN D. PELHAM, P.E.
GARZA EMC
7708 RIALTO BLVD STE. 125
AUSTIN, TEXAS 78735
(512) 298-3284

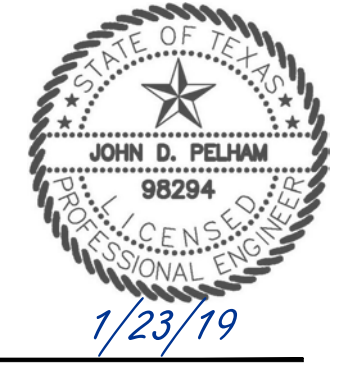

WATERSHED STATUS:
THIS SITE IS LOCATED WITHIN THE WALNUT CREEK WATERSHED, WHICH IS CLASSIFIED BY THE CITY OF AUSTIN AS A SUBURBAN WATERSHED. THIS SITE IS NOT LOCATED OVER THE EDWARDS AQUIFER RECHARGE ZONE.

FLOODPLAIN INFORMATION:
NO PORTION OF THIS SITE IS LOCATED WITHIN THE 100 YEAR FLOODPLAIN ACCORDING TO FIRM PANEL No. 48453C0265J, EFFECTIVE AUGUST 18, 2014

LEGAL DESCRIPTION:
LOT 1 BLOCK "B" OF IBM SUBDIVISION EAST RECORDED IN VOLUME 94, PAGE 88 OF THE PLAT RECORDS OF TRAVIS COUNTY, TEXAS.

BENCHMARK NOTE:
REFERENCE PRELIMINARY PLAN SHEET 2 FOR BENCHMARK INFORMATION

NOTE:
APPROVAL OF THIS PRELIMINARY PLAN DOES NOT CONSTITUTE APPROVAL OF ANY DEVIATION FROM THE CITY'S LAND DEVELOPMENT REGULATIONS IN THE FINAL PLAT, CONSTRUCTION PLAN OR SITE PLAN STAGE, UNLESS SUCH DEVIATIONS HAVE BEEN SPECIFICALLY REQUESTED IN WRITING AND SUBSEQUENTLY APPROVED IN WRITING BY THE CITY. SUCH APPROVALS DO NOT RELIEVE THE ENGINEER OF THE OBLIGATION TO MODIFY THE DESIGN OF THE PROJECT IF IT DOES NOT MEET ALL OTHER CITY AND LAND DEVELOPMENT REGULATIONS OR IF IT IS SUBSEQUENTLY DETERMINED THE DESIGN WOULD ADVERSELY IMPACT THE PUBLIC SAFETY, HEALTH, WELFARE OF PROPERTY.

ALL RESPONSIBILITY FOR THE ADEQUACY OF THESE PLANS REMAIN WITH THE ENGINEER WHO PREPARED THEM. IN REVIEWING THESE PLANS, THE CITY OF AUSTIN MUST RELY UPON THE ADEQUACY OF.

SUBDIVISION No: C8-93-0029.OA
ZONING ORDINANCE No.: 20090312-036



7708 Rialto Blvd., Suite 125
Austin, Texas 78735
Tel. (512) 298-3284 Fax (512) 298-2592
TBPE # F-14629 TBPLS # F-10193841
Garza EMC, LLC © Copyright 2018



Page Southernland Page, Inc.
pagestink.com
TEL: (512) 472-6721
FAX: (512) 477-3211
ARCHITECTURE / ENGINEERING / INTERIORS / CONSULTING
Austin / Dallas / Denver / Houston / Washington DC / International Affiliate Offices

I, JOHN D. PELHAM, P.E., CERTIFY THAT THESE ENGINEERING DOCUMENTS ARE COMPLETE, ACCURATE AND ADEQUATE FOR THE INTENDED PURPOSES, INCLUDING CONSTRUCTION, BUT ARE NOT AUTHORIZED FOR CONSTRUCTION PRIOR TO FORMAL CITY APPROVAL.

FILE: V:\102746\10004\CD DWG\PH1\Preliminary Plan\102746004-CVR.dwg

FOR CITY USE ONLY:

PRELIMINARY SUBDIVISION APPROVAL Sheet ___ of ___
FILE NUMBER: C8-93-0029 APPLICATION DATE: JANUARY 11, 2018
APPROVED BY PC ON: _____ UNDER SECTION 112 OF
CHAPTER 25-5 OF THE CITY OF AUSTIN CODE.
EXPIRATION DATE (LDC 25-4-62) JANUARY 11, 2023
CASE MANAGER STEVE HOPKINS

J. Rodney Gonzales, Director, Development Services Department

FINAL PLAT MUST BE RECORDED BY THE PROJECT EXPIRATION DATE. SUBSEQUENT SITE PLANS WHICH DO NOT COMPLY WITH THE CODE CURRENT AT THE TIME OF FILING, AND REQUIRE BUILDING PERMITS OR NOTICE OF CONSTRUCTION (IF BUILDING PERMIT IS NOT REQUIRED), MUST ALSO BE APPROVED PRIOR TO PROJECT EXPIRATION DATE.

SHEET
01
OF 3

V:\102746\10004\CD DWG\PH1\Preliminary Plan\102746004-CVR.dwg modified by subussie on May 7, 15:3:16 PM

CHARLES SCHWAB SUBDIVISION

BEING A RESUBDIVISION OF LOT 1, BLOCK "B", IBM SUBDIVISION EAST,
SITUATED IN THE JAMES RODGERS NO. 19 SURVEY, CITY OF AUSTIN, TRAVIS COUNTY, TEXAS.

GENERAL NOTES:

1. NO LOT IN THIS SUBDIVISION SHALL BE OCCUPIED UNTIL THE STRUCTURES IS CONNECTED TO THE CITY OF AUSTIN WATER AND WASTEWATER SYSTEM.
2. THE WATER AND WASTEWATER UTILITY SYSTEM SERVING THIS SUBDIVISION MUST BE IN ACCORDANCE WITH THE CITY OF AUSTIN UTILITY DESIGN CRITERIA. THE WATER AND WASTEWATER UTILITY PLAN MUST BE REVIEWED AND APPROVED BY AUSTIN WATER. ALL WATER AND WASTEWATER CONSTRUCTION MUST BE INSPECTED BY THE CITY OF AUSTIN. THE LANDOWNER MUST PAY THE CITY INSPECTION FEE WITH THE UTILITY CONSTRUCTION.
3. ALL PUBLIC AND PRIVATE STREETS, DRAINAGE, SIDEWALKS, WATER AND WASTEWATER LINES, AND EROSION CONTROLS SHALL BE CONSTRUCTED AND INSTALLED TO CITY OF AUSTIN STANDARDS.
4. PROPERTY OWNERS SHALL PROVIDE FOR ACCESS TO DRAINAGE EASEMENTS AS MAY BE NECESSARY AND SHALL NOT PROHIBIT ACCESS BY GOVERNMENTAL AUTHORITIES.
5. PUBLIC SIDEWALKS ARE REQUIRED ALONG ALL INTERNAL STREETS AND THE SUBDIVISION SIDE OF GRACY FARMS LANE AS SHOWN BY A DOTTED LINE ON THE FACE OF THE PLAT. THE REQUIRED SIDEWALKS SHALL BE IN PLACE PRIOR TO THE LOT BEING OCCUPIED. FAILURE TO CONSTRUCT THE REQUIRED SIDEWALKS MAY RESULT IN THE WITHHOLDING OF CERTIFICATES OF OCCUPANCY, BUILDING PERMITS, OR UTILITY CONNECTIONS BY THE GOVERNING BODY OR UTILITY COMPANY.
6. NO BUILDINGS, FENCES, LANDSCAPING OR OTHER STRUCTURES ARE PERMITTED IN DRAINAGE EASEMENTS EXCEPT AS APPROVED BY THE CITY OF AUSTIN.
7. PRIOR TO CONSTRUCTION, EXCEPT FOR ATTACHED AND DETACHED SINGLE FAMILY RESIDENTIAL, A SITE DEVELOPMENT PERMIT MUST BE OBTAINED FROM THE CITY OF AUSTIN (LDC CHAPTER 25-5-1).
8. AUSTIN ENERGY HAS THE RIGHT TO PRUNE AND OR REMOVE TREES, SHRUBBERY OR OTHER OBSTRUCTIONS TO THE EXTENT NECESSARY TO KEEP EASEMENTS CLEAR. AUSTIN ENERGY WILL PERFORM ALL TREE WORK IN COMPLIANCE WITH CHAPTER 25-8, SUBCHAPTER B OF THE CITY OF AUSTIN LAND DEVELOPMENT CODE.
9. BUILDING SETBACK REQUIREMENTS SHALL COMPLY WITH THOSE SET FORTH IN CITY OF AUSTIN LAND DEVELOPMENT CODE.
10. PRIOR TO THE RECORDING OF THE FINAL PLAT OF ALL OR A PORTION OF THIS PRELIMINARY PLAN, FISCAL SECURITY SHALL BE PROVIDED IN ACCORDANCE WITH SECTION 25-1-112 OF THE CITY OF AUSTIN LAND DEVELOPMENT CODE OR BY THE USE OF A FISCAL POSTING CREDIT BANK AS APPROVED BY THE CITY FOR THE FOLLOWING IMPROVEMENTS:
 - A. STREET CONSTRUCTION AND RELATED INFRASTRUCTURE, INCLUDING PAVING, AND DRAINAGE, SIDEWALKS FOR THE FOLLOWING STREETS: SCHWAB WAY. FISCAL SURETY IS NOT REQUIRED FOR STREETS NOT LISTED IN THIS SUBSECTION.
 - B. ENVIRONMENTAL AND SAFETY CONTROLS, AND OTHER RELATED ITEMS (E.G. EROSION AND SEDIMENTATION CONTROLS, RESTORATION, CHANNEL WORK, PIPE IN EASEMENT, DETENTION, WATER QUALITY POND, ETC.) AS DETERMINED PRIOR TO FINAL PLAT APPROVAL. THE RESTORATION COST ESTIMATE WILL BE BASED ON DISTURBED AREAS INCLUDING THE FOLLOWING STREETS: SCHWAB WAY.
12. THE OWNER OF THIS SUBDIVISION, AND HIS OR HER SUCCESSORS AND ASSIGNS, ASSUMES RESPONSIBILITY FOR THE PLANS FOR CONSTRUCTION OF SUBDIVISION IMPROVEMENTS WHICH COMPLY WITH APPLICABLE CODES AND REQUIREMENTS OF THE CITY OF AUSTIN. THE OWNER UNDERSTANDS AND ACKNOWLEDGES THAT PLAT VACATION OR REPLATING MAY BE REQUIRED AT THE OWNER'S SOLE EXPENSE, IF PLANS TO CONSTRUCT THIS SUBDIVISION DO NOT COMPLY WITH SUCH CODES AND REQUIREMENTS.
13. PRIOR TO CONSTRUCTION ON LOTS IN THIS SUBDIVISION, DRAINAGE PLANS WILL BE SUBMITTED TO THE CITY OF AUSTIN FOR REVIEW. RAINFALL RUN-OFF SHALL BE HELD TO THE AMOUNT EXISTING BY PONDING OR OTHER APPROVED METHODS.
14. OWNER'S ENGINEER SHALL PROVIDE A CONSTRUCTION COST ESTIMATE FOR SUBDIVISION INFRASTRUCTURE IMPROVEMENTS AT THE TIME OF SUBDIVISION IMPROVEMENT CONSTRUCTION PLAN SUBMITTAL. OWNER SHALL PAY THE SUBDIVISION ENGINEERING REVIEW FEE PRIOR TO APPROVAL OF CONSTRUCTION PLANS.
15. ELECTRICAL AND TELECOMMUNICATION EASEMENTS WILL BE DEDICATED AT TIME OF FINAL PLAT.
16. WITHIN A SIGHT DISTANCE EASEMENT ANY OBSTRUCTION OF SIGHT DISTANCE BY VEGETATION, FENCING, EARTHWORK, BUILDINGS, SIGNS, PARKED CARS, OR ANY OTHER OBJECT THAT IS DETERMINED TO CAUSE A TRAFFIC HAZARD IS PROHIBITED AND MAY BE REMOVED BY THE CITY OF AUSTIN AT THE OWNER'S EXPENSE. THE PROPERTY OWNER IS REQUIRED TO MAINTAIN AN UNOBSTRUCTED VIEW CORRIDOR WITHIN THE BOUNDS OF SUCH EASEMENTS AT ALL TIMES.
17. ALL ACTIVITIES WITHIN THE CRITICAL ENVIRONMENTAL FEATURE AND ASSOCIATED SETBACK MUST COMPLY WITH THE CITY OF AUSTIN LAND DEVELOPMENT CODE. THE NATURAL VEGETATIVE COVER MUST BE RETAINED TO THE MAXIMUM EXTENT PRACTICABLE; CONSTRUCTION IS PROHIBITED; AND WASTEWATER DISPOSAL OR IRRIGATION IS PROHIBITED.
18. STANDARD STREET NAME SIGNS WILL BE INSTALLED AT ALL PRIVATE STREET INTERSECTIONS. AN ADDITIONAL "PRIVATE STREET" SIGN WILL BE POSTED AT ALL INTERSECTIONS OF PRIVATE STREETS WITH PUBLIC STREETS.

STANDARD PLAT NOTES:

1. EROSION/SEDIMENTATION CONTROLS ARE REQUIRED FOR ALL CONSTRUCTION ON EACH LOT, PURSUANT TO LDC SECTION 25-8-181, AND THE ENVIRONMENTAL CRITERIA MANUAL.
2. IN A SUBURBAN WATERSHED WATER QUALITY CONTROLS ARE REQUIRED IN ACCORDANCE WITH THE ENVIRONMENTAL CRITERIA MANUAL, AND NEW DEVELOPMENT MUST PROVIDE FOR REMOVAL OF FLOATING DEBRIS FROM STORMWATER RUNOFF AS PER LDC 25-8-211

BENCHMARKS:

- ELEVATIONS HEREON ARE REFERENCED TO THE NORTH AMERICAN VERTICAL DATUM OF 1988 (NAVD 88) UTILIZING WESTERN DATA SYSTEMS CONTINUALLY OPERATING REFERENCE STATION (CORS) NETWORK.
- TBM A
PK NAIL WITH WASHER SET IN SIDEWALK ±11' NORTH OF CURB OF GRACY FARMS LANE, ACROSS THE STREET FROM SITE ENTRANCE/EXIT.
ELEVATION=730.71' (AS SHOWN)
- TBM B
PK NAIL WITH WASHER SET IN SIDEWALK ON WEST SIDE OF ROAD TO GRACY FARMS LANE, BEING ±600 FEET SOUTH OF GRACY FARMS LANE AND ±77' SOUTH OF DRIVEWAY.
ELEVATION=744.35' (AS SHOWN)
- TBM C
ALUMINIUM DISK IN CONCRETE PAD ±10' BEHIND EASTERLY CURB LINE OF ROAD TO GRACY FARMS LANE, BEING ±1500' SOUTH OF GRACY FARMS LANE AND ±34' WEST OF PECAN TREE (TAGGED 4305)
ELEVATION=755.62' (AS SHOWN)
- TBM D
PK NAIL WITH WASHER SET IN BACK OF CURB AT SOUTHEAST SIDE OF BRICK PAVER TURN AROUND AT TIVOLI BUILDING AND ±7' NORTHWEST
ELEVATION=746.64' (AS SHOWN)

LAND USE TABLE		
LAND USE	LOTS	AREA (AC)
OFFICE	1	48.64
PRIVATE STREET	1	1.85
TOTAL	2	50.49

TYPICAL STREET SECTION:

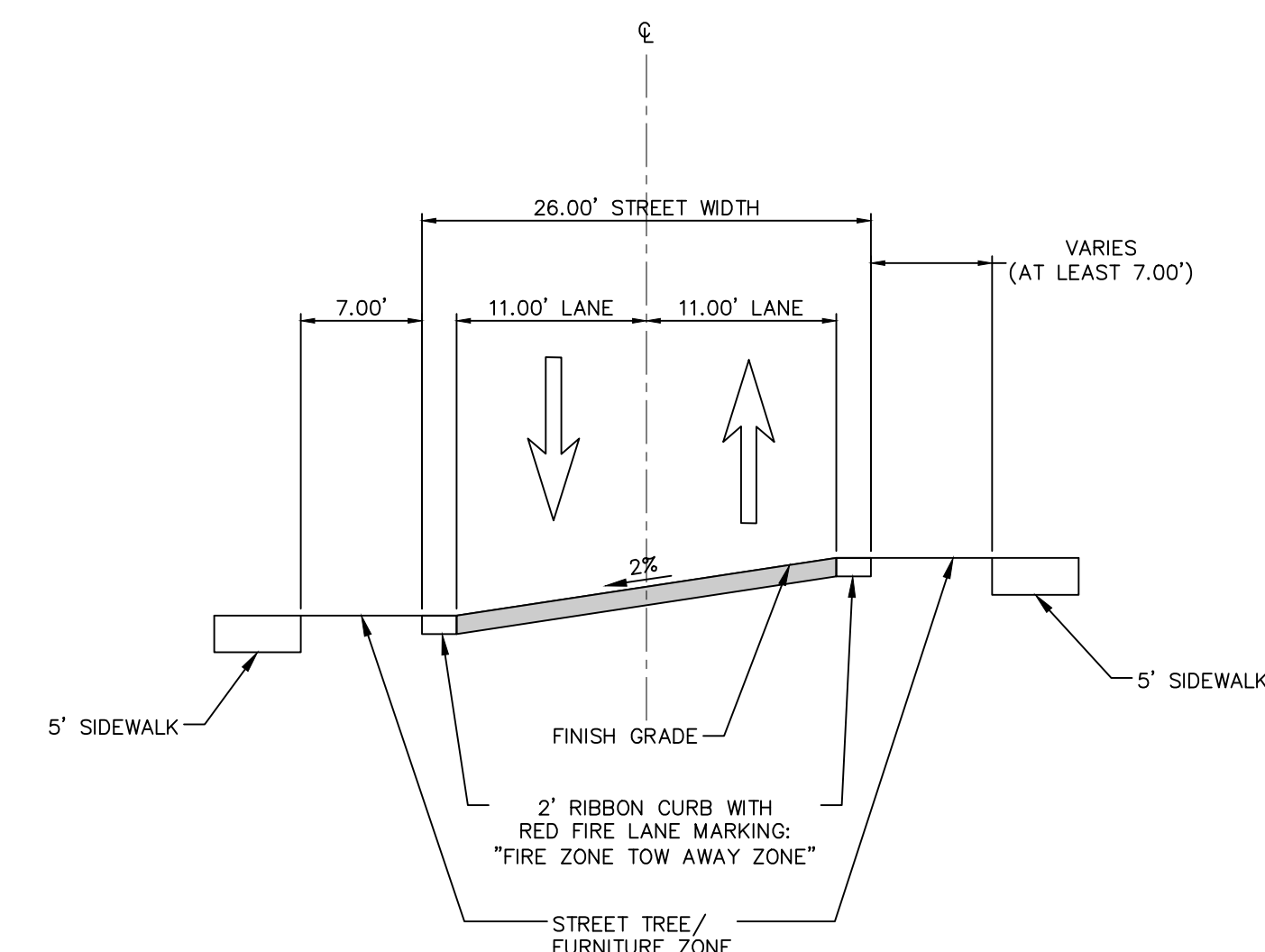

STREET TABLE						
NAME OF STREET	PAVEMENT WIDTH	CROSS-SECTION	SIDEWALK	PAVEMENT EDGE	CLASSIFICATION SECTION TYPE	LINEAR FOOTAGE
SCHWAB WAY (PRIVATE STREET)	2 LANE	SUPPERELEVATED	5'	LAYDOWN CURB	COMMERCIAL COLLECTOR	±865

CHARLES SCHWAB AUSTIN CORPORATE CAMPUS
LOT 1
WALNUT CREEK WATERSHED (SUBURBAN CITY LIMITS)

APPENDIX Q-2: IMPERVIOUS COVER SUBURBAN WATERSHEDS
NOTE: Q1 TABLES ARE NOT REQUIRED FOR SUBURBAN WATERSHEDS

Impervious cover allowed at 80 % X GSA = 38.91 Acres

ALLOWABLE IMPERVIOUS COVER BREAKDOWN BY SLOPE CATEGORY

Total acreage 15-25% =	2.30 Acres X 10% =	0.23 Acres
PROPOSED TOTAL IMPERVIOUS COVER		
Total proposed impervious cover =	19.37 Acres =	39.8 %

PROPOSED IMPERVIOUS COVER ON SLOPES

SLOPE CATEGORIES	ACRES	BUILDING/AND OTHER IMPERVIOUS COVER		DRIVEWAYS/ROADWAYS	
		AC.	% OF CATEGORY	AC.	% OF CATEGORY
0-15%	43.64	12.37	28.4%	7	16.0%
15-25%	2.30	0		0	
25-35%	1.60	0		0	
Over 35%	1.10	0		0	
TOTAL SITE AREA	48.64				

CHARLES SCHWAB AUSTIN CORPORATE CAMPUS
LOT 2
WALNUT CREEK WATERSHED (SUBURBAN CITY LIMITS)

APPENDIX Q-2: IMPERVIOUS COVER SUBURBAN WATERSHEDS
NOTE: Q1 TABLES ARE NOT REQUIRED FOR SUBURBAN WATERSHEDS

Impervious cover allowed at 80 % X GSA = 1.48 Acres

ALLOWABLE IMPERVIOUS COVER BREAKDOWN BY SLOPE CATEGORY

Total acreage 15-25% =	0.00 Acres X 10% =	0.00 Acres
PROPOSED TOTAL IMPERVIOUS COVER		
Total proposed impervious cover =	0.88 Acres =	47.3 %

PROPOSED IMPERVIOUS COVER ON SLOPES

SLOPE CATEGORIES	ACRES	BUILDING/AND OTHER IMPERVIOUS COVER		DRIVEWAYS/ROADWAYS	
		AC.	% OF CATEGORY	AC.	% OF CATEGORY
0-15%	1.85	0.10	5.6%	0.77	41.7%
15-25%	0.00	0		0	
25-35%	0.00	0		0	
Over 35%	0.00	0		0	
TOTAL SITE AREA	1.85				

DATE	NO.	REVISION	APPROVAL

7708 Radio Blvd., Suite 125
Austin, TX 78758
Tel: (512) 298-2324 Fax: (512) 298-2592
TBE# F-14429
Garza ENC, LLC © Copyright 2019

**PRELIMINARY PLAN
GENERAL NOTES**

**CHARLES SCHWAB
AUSTIN CORPORATE CAMPUS
2309 GRACY FARMS LANE
AUSTIN, TX 78758**

DRAWN BY: JV
DESIGNED BY: WZ
QA / QC: JP
PROJECT NO.: 1027460004

FOR CITY USE ONLY:

PRELIMINARY SUBDIVISION APPROVAL Sheet ___ of ___
FILE NUMBER: **08-8018-0005** APPLICATION DATE: JANUARY 11, 2018
APPROVED BY PC ON: _____ UNDER SECTION 112 OF
CHAPTER 25-5 OF THE CITY OF AUSTIN CODE.
EXPIRATION DATE (LDC 25-4-62) JANUARY 11, 2023
CASE MANAGER STEVE HOPKINS

J. Rodney Gonzales, Director, Development Services Department

FINAL PLAT MUST BE RECORDED BY THE PROJECT EXPIRATION DATE. SUBSEQUENT SITE PLANS WHICH DO NOT COMPLY WITH THE CODE CURRENTLY AT THE TIME OF FILING, AND REQUIRE BUILDING PERMITS OR NOTICE OF CONSTRUCTION (IF BUILDING PERMIT IS NOT REQUIRED), MUST ALSO BE APPROVED PRIOR TO PROJECT EXPIRATION DATE.

SHEET
02
OF 3

CHARLES SCHWAB SUBDIVISION
 BEING A RESUBDIVISION OF LOT 1, BLOCK B, IBM SUBDIVISION EAST,
 SITUATED IN THE JAMES RODGERS NO. 19 SURVEY, CITY OF AUSTIN, TRAVIS COUNTY, TEXAS.

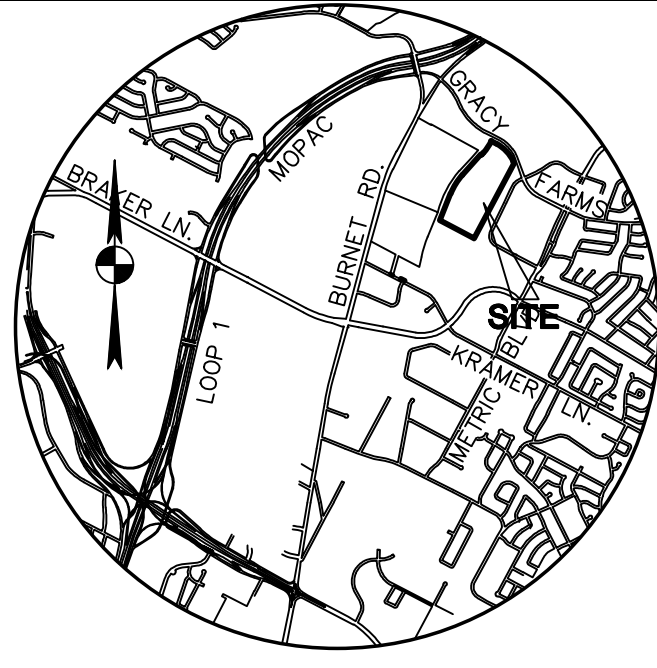

LOT 1, BLOCK "A"
 REPLAT OF LOT 1, JEFFERSON AT
 STONE HOLLOW
 VOLUME 97, PAGES 180-181

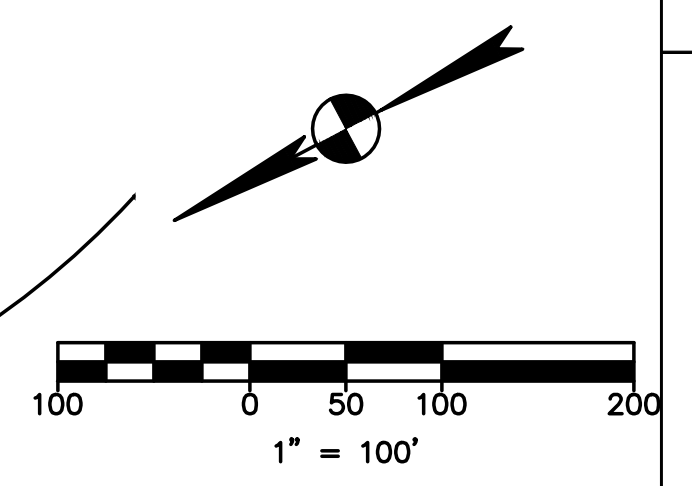

- LEGEND**
- 1/2" IRON ROD FOUND
 - CAP
 - SUBLT SQUARE BOLT FOUND
 - IRON PIPE FOUND
 - 1/2" IRON ROD WITH "STANTEC" CAP SET
 - SPINDLE COTTON SPINDLE FOUND
 - SIDEWALK

garza
 7708 Radio Blvd., Suite 125
 Austin, TX 78758
 Tel: (512) 298-2324 Fax: (512) 298-2592
 TDD: (512) 298-2324
 Garza EMC, LLC © Copyright 2019

APPROVAL
 JOHN D. PELJAM
 98294
 1/23/19

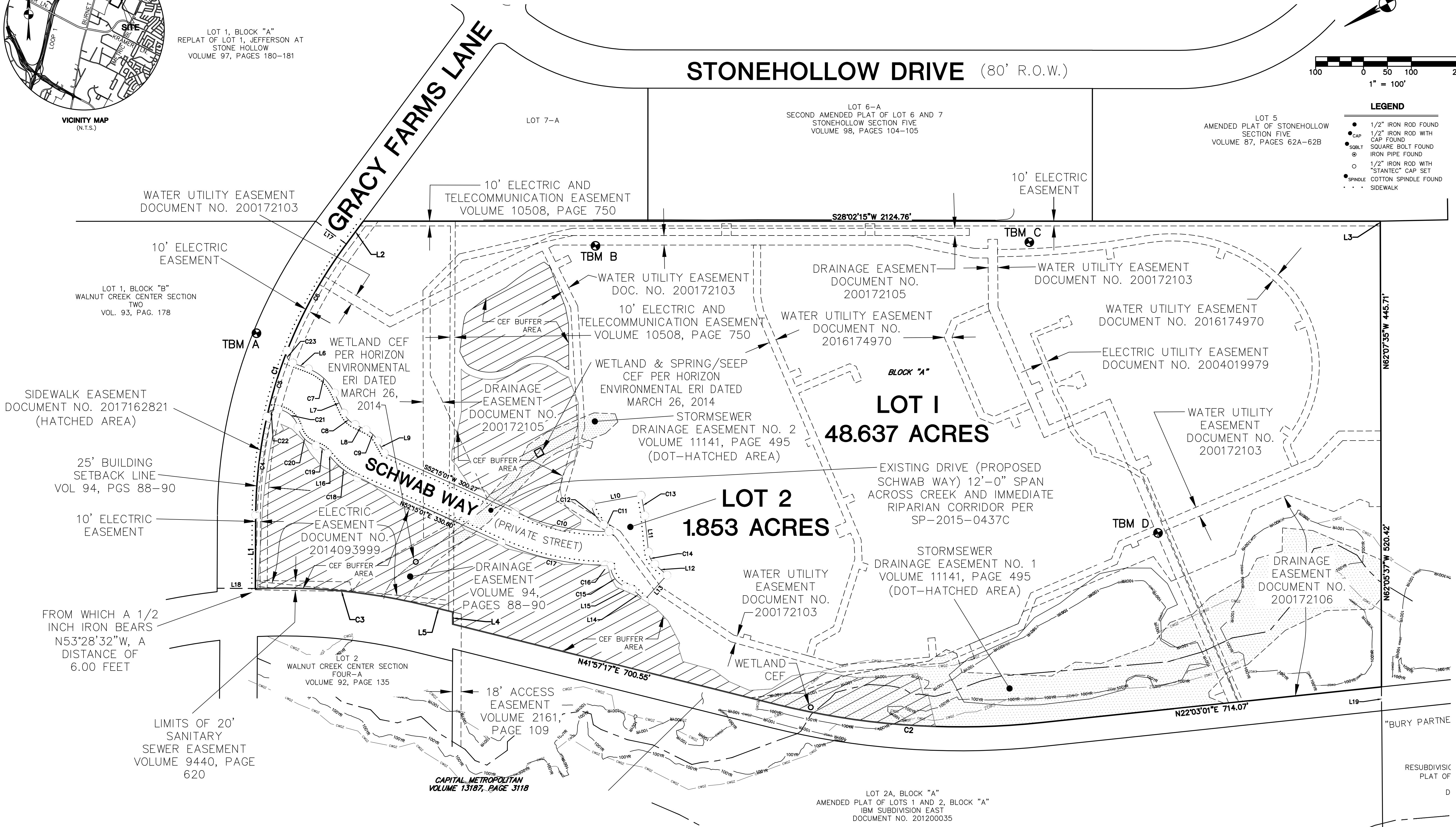

PRELIMINARY PLAN

CHARLES SCHWAB
 AUSTIN CORPORATE CAMPUS
 2309 GRACY FARMS LANE
 AUSTIN, TX 78758

LINE TABLE

NO.	BEARING	DISTANCE
L1	S61°40'10"E	154.09'
L2	S25°16'18"E	59.58'
L3	N62°13'28"W	7.20'
L4	S61°48'24"E	25.60'
L5	N41°45'49"E	60.89'
L6	S48°34'56"W	34.93'
L7	S86°53'23"E	46.43'
L8	S53°49'06"W	25.41'
L9	S89°36'42"W	28.61'
L10	S17°56'39"W	105.75'

LINE TABLE

NO.	BEARING	DISTANCE
L11	N67°51'11"W	76.14'
L12	S70°06'49"W	34.39'
L13	N19°53'11"W	70.00'
L14	N70°06'49"E	34.39'
L15	N46°34'29"E	13.98'
L16	N77°56'04"E	14.12'
L17	N64°42'16"E	79.80'
L18	N28°19'43"E	79.72'
L19	N62°05'37"W	49.91'

CURVE TABLE

NO.	LENGTH	RADIUS	DELTA	CHORD BEARING	CHORD LENGTH
C1	607.29'	955.80'	36°24'15"	S43°28'14"E	597.13'
C2	554.54'	1590.71'	19°58'27"	N31°53'15"E	551.74'
C3	356.16'	1247.29'	16°21'39"	N33°32'32"E	354.95'
C4	207.37'	955.80'	12°25'51"	S55°27'26"E	206.96'
C5	144.62'	955.80'	8°40'10"	S44°54'26"E	144.48'
C6	255.30'	955.80'	15°18'15"	S32°55'13"E	254.54'
C7	76.16'	98.00'	44°31'40"	S70°50'47"W	74.26'
C8	34.29'	50.00'	39°17'31"	S73°27'51"W	33.62'
C9	34.36'	55.00'	35°47'36"	S71°42'54"W	33.80'
C10	201.53'	465.00'	24°49'55"	S39°50'03"W	199.96'
C11	18.82'	28.53'	37°47'27"	N80°48'05"E	18.48'
C12	51.25'	60.76'	48°19'34"	N86°43'16"E	49.75'

CURVE TABLE

NO.	LENGTH	RADIUS	DELTA	CHORD BEARING	CHORD LENGTH
C13	43.09'	605.00'	4°04'51"	N72°09'11"W	43.08'
C14	29.34'	40.00'	42°02'00"	N88°52'11"W	28.69'
C15	57.58'	48.08'	68°37'05"	N81°45'17"E	54.20'
C16	11.55'	38.00'	17°25'07"	N36°57'06"E	11.51'
C17	223.00'	535.00'	23°52'55"	N40°18'33"E	221.39'
C18	67.24'	150.00'	25°41'04"	S65°05'33"W	66.68'
C19	29.11'	50.00'	33°21'12"	N61°15'28"E	28.70'
C20	56.56'	55.00'	58°55'28"	N74°02'36"E	54.10'
C21	58.36'	50.50'	66°13'02"	S70°14'24"W	55.17'
C22	31.65'	20.00'	90°41'05"	N03°53'58"W	28.45'
C23	31.71'	19.98'	90°54'49"	N85°58'44"W	28.49'

CHARLES SCHWAB SUBDIVISION
 A 2 LOT SUBDIVISION
 CONSISTING OF 50.490 ACRES
 DATE: DECEMBER 2017
 PREPARED BY:

FOR CITY USE ONLY:

PRELIMINARY SUBDIVISION APPROVAL Sheet _____ of _____
 FILE NUMBER: **08-8018-0005** APPLICATION DATE: JANUARY 11, 2018
 APPROVED BY PC ON: _____ UNDER SECTION 112 OF
 CHAPTER 25-5 OF THE CITY OF AUSTIN CODE.
 EXPIRATION DATE (LDC 25-4-62) JANUARY 11, 2023
 CASE MANAGER: **STEVE HOPKINS**

J. Rodney Gonzales, Director, Development Services Department

FINAL PLAT MUST BE RECORDED BY THE PROJECT EXPIRATION DATE. SUBSEQUENT SITE PLANS WHICH DO NOT COMPLY WITH THE CODE CURRENT AT THE TIME OF FILING, AND REQUIRING BUILDING PERMITS OR NOTICE OF CONSTRUCTION (IF BUILDING PERMIT IS NOT REQUIRED), MUST ALSO BE APPROVED PRIOR TO PROJECT EXPIRATION DATE.

DRAWN BY: JV
 DESIGNED BY: NZ
 QA / QC: JP
 PROJECT NO.: 10274600004

SHEET 03
 OF 3